



INSTALLATION AND OPERATING MANUAL

Refrigerated Merchandisers with Air-Over Displays



**Refrigerated
Low-Profile
Mobile Merchandiser**



**Refrigerated
High-Profile
Mobile Merchandiser**



**Refrigerated
Grab-N-Go
Merchandiser**



**Refrigerated
End Cap
Merchandiser**

FOR PARTS & SERVICE
Contact: Piper Products, Inc.
Phone: (800) 544-3057
Ask for Service Department

IMPORTANT!

This manual contains important safety information concerning the maintenance, use and operation of this product. Failure to follow these instructions could result in damaging equipment, voiding the warranty, serious injury or even death.

Installation and Operating Manual

Refrigerated Cases with Air-Over Displays

Refrigerated Mobile Merchandiser

Refrigerated Grab-N-Go

Refrigerated End Cap Merchandiser

Refrigerated Island Merchandiser

Table of Contents

Installation and Operation:

Safe Electrical Installation	3
Safe Electrical Installation (Remote Units Only)	3
Safe Plumbing Installation	4
Safe Refrigeration Installation (Remote Units Only)	4
Temperature Settings for Air-Over Display Units	4
Dixell Settings/Air-Over Units & Under Counter Refrigerators	5
Operation Instructions for Cold Food Units	6
Loading	6
Preventative Maintenance	8
Wiring Diagram	9
Warranty	10

Safe Electrical Installation

- If the unit uses an electrical plug, always connect to a properly grounded electrical outlet of correct voltage, size and plug confirmation.
- If the unit requires an electrical line to be connected to an internal load center or junction box, have a qualified electrician perform the installation.
- Always follow local, state, federal, and NEC electrical and plumbing codes to ensure compliance.
- Units with a 20 amp NEMA 5-20 plug must be powered by a dedicated circuit.
- All servicing which requires access to non-insulated electrical components must be performed by a factory authorized technician.
- Do not operate the unit if the electrical components appear damaged.
- Check the rating label for electrical rating.
- If the unit has an external powered condensation pan, the pan must be powered by a secondary receptacle.

Safe Electrical Installation (Remote Units Only)

- Disconnect power before servicing or working on the unit.
- Consult an electrician for proper installation.
Caution—Risk of Electrical Shock.
- Make the electrical connections after the sections of the counter have been physically secured together.
- Wherever two counter sections mate, one section will be provided with wires routed in conduit which terminate in a junction box. The other section will be provided with wires routed in conduit which either terminate in a junction box or extend approximately 6 in. (15.2 cm) from the end of the conduit.
- If the wires in both sections of the counter terminate in junction boxes, the provided fitting should be used to secure the two junction boxes together. The wires in one of the junction boxes should be routed through the fitting into the other junction box.
- If the wires in one of the sections do not terminate in a junction box, the wires that extend from the end of the conduit are to be routed through the opening provided into the junction box to the other section. The conduit is to be secured to the junction box with the provided fitting.
- The leads in the junction box are to be matched-up according to the identifying stickers on the lead ends.
- All electrical connections are to be made in the junction box.
- The junction box cover is to be secured in place.

Safe Plumbing Installation

- If the unit requires a drain, have a qualified plumber perform the installation.
- Some jurisdictions may require an approved air gap or other flow back prevention device in the drain.

Safe Remote Refrigeration Installation (Remote Units Only)

- If the unit requires a remote condenser, have a qualified refrigeration technician connect the suction and liquid line to the facilities system. For units with two cold pans, there are two options:
 - 1) Run two suction and two liquid supply lines so each cold pan gets independently connected.
 - 2) Run a single suction and a single liquid supply line to a tee and connect each cold pan from the tee. Be sure the single suction and single liquid lines are large enough to accommodate both pans.
- Be sure to use the correct refrigerant and to have the solenoid valve for each cold section/cold pan installed.
- Each cold section/cold pan has a thermostat that needs to be set correctly. See the Factory Settings table in the ***Operations for Cold Food Units*** section of this manual.
- Once the connections are made, the unit must be evacuated to -400 microns and hold for 1 hour.
- Have the technician perform a sniff and leak test to ensure the connection is complete.

Temperature settings for Display units:

R&D Fixtures' refrigerated units have two (2) different configurations.

1. On a unit with the temperature probe in the coil - sensing ***coil temperature***:
The SET point is 20° F.
This allows the unit to produce a discharge air temperature @ 30°
2. On a unit with the probe in the discharge - sensing ***discharge air temperature***:
The SET point is 30° F.
This allows the unit to maintain a product temperature of 36° to 38°.

The defrost settings on these units are identical. The defrost termination probe must be placed in the evaporator coil to be able to sense the coil temperature and allow the controller to bring the unit out of defrost when the coil has reached an ice free temperature.

The temperature settings may have to be slightly adjusted on individual units depending on the store's ambient air temperature and moisture level.

Always remember that this unit is designed to *maintain* a product's temperature. It is not designed to bring a warm product's temperature to the required refrigerated level. All product placed in this unit must be at 38° or below for the unit to maintain a safe temperature.

Blocking the return air grills on these units will cause a freeze up of the evaporator coil and voids the warranty.

Never stack product in a way that blocks the air flow from the unit. Maintaining a good air flow allows this unit to run more efficiently.

RECOMMENDED DIXELL SETTINGS

Dixell Settings

Mobile Merchandiser, Grab-N-Go and other air over displays:

If the probes are both in the Evaporator coil please start with the following settings:

SET=22°	This is the temperature set point, adjust in 2° increments and adjust HY as needed.
HY = 12°	This is the temp differential. When added to the set point the total should be 34°
Ot = 0	This is probe calibration 0 unless adjusted by trained tech.
P2P = Y	This signifies the defrost termination probe is present.
AC = 2 or 3	This is the anti short cycle setting. 2 or 3 minutes between starts.
rES = in	This is a resolution setting and should not be changed.
tdF = EL	This is the setting for type of defrost. EL is electric and uses the fans to defrost.
dtE = 42°	This is the defrost termination setting. At 40° the unit comes out of defrost.
ldF = 6	This is the interval between defrost - 6 being every 6 hours.
MdF = 60	This is the Max. Defrost length.

* The Temperature setting (SET) and temp differential (HY) work together. If the Set point number is increased, the temp differential needs to be decreased so that the total of the two still equals 34° Likewise, if the SET temperature is decreased, the temp differential (HY) must be increased so the the two numbers still equal 34°

Temperature setting:

Factory Temperature Setting is 22°

To set the temperature, first press and release the SET button. This will show the current set point.

To adjust the temperature, press and hold the SET button until the display shows the set point. Once the current set point is visible, use the up or down arrows to change the setting.

When the new set point has been reached, press the SET button one more time.

Parameter set point changes:

- Access the parameter settings by pressing SET and the Down arrow at the same time until HY appears.
- Press the SET button again to go to the setting for HY.
- By pressing SET the label appears, then the set point.
- If a change is made to a set point, press SET - when the set point flashes, move to the next label.
- When the last change has been made, wait about 10 seconds and the controller will move back into the operation mode.

The length of time the unit remains in the defrost cycle is based on the termination set point. When the controller senses that the unit has reached 40° F the defrost cycle is ended and the refrigeration cycle starts again. If the unit does not reach 40° it will restart the refrigeration cycle after defrosting for 60 minutes.

We welcome your call for assistance setting the controls on your merchandiser. Please don't hesitate to call. Please refer to contact numbers on back cover.

Operation Instructions for Cold Food Units

- **Self-contained units** should be turned on and allowed to cycle twice before adding product. See the section entitled: Dixell Settings for instructions on how to set temperature.
- **Remote units** should be turned on and allowed to cycle two times after super-heat is adjusted before adding product. See the section entitled: Dixell Settings for instructions on how to set temperature.

Location of the Merchandiser

These merchandisers are designed for displaying products in air-conditioned stores where temperature is maintained at or below the ANSI/NSF-7 specified level and relative humidity is maintained at or below 55%.

Placing the units in direct sunlight, near hot tables or near other heat sources could impair their efficiency.

These merchandisers are sensitive to ambient air conditions. Air currents passing around the units can seriously impair their operation. Do NOT allow air conditioning, electric fans, open doors or windows, etc. to create air currents around the merchandisers.

Loading

Merchandise should not be placed into the fixture until all the controls have been adjusted and the case is at the proper temperature. **THE CASE SHOULD NEVER BE STOCKED BEYOND THE LOAD LINE OR THE FRONT EDGE OF THE ADJUSTABLE SHELVES.**

Air discharge and return flues must remain open and free of debris or obstruction at all times to provide proper refrigeration and air current performance. Do not use any non-approved shelving, display racks or accessory that could hamper air current performance.

Leave approximately 1" space around product containers.

Rotate product regularly with new product placed at the back and older product moved to the front of the shelves.

- On **air-cooled units** (air-over/air-under) with refrigerated display for packaged food:
 - containers should not be stacked more than 2 levels high.
 - product should be placed about 1" from the back wall and have about 1" spacing between each product container to allow cold air flow around all sides of product.

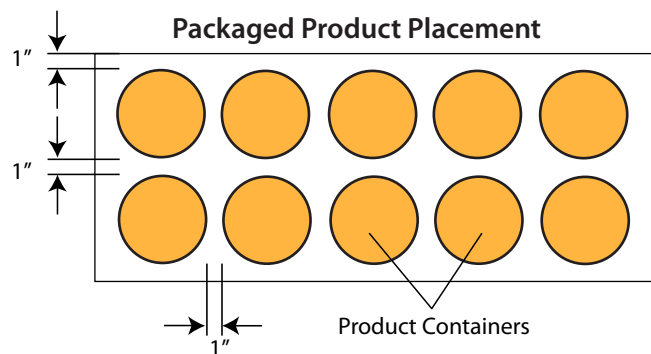

A Refrigerated Air Curtain (flow) creates a COLD CONTAINMENT AREA within each unit.

Merchandise must not be stacked beyond the price tag molding on merchandiser shelving and must be low enough so that the refrigeration air curtain is not broken.

Over-stacking product or displaying product that is too tall for the area deflects refrigerated air flow,

pushing it into the area surrounding the merchandiser and creating warm zones. This makes the compressor work harder to maintain temperature, wastes energy and creates an inefficient cooling environment.

Loading Mobile Merchandisers

Correct

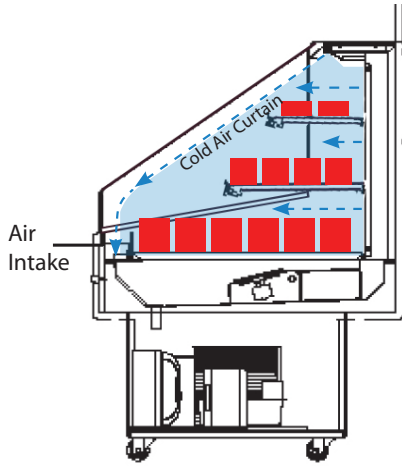

Wrong

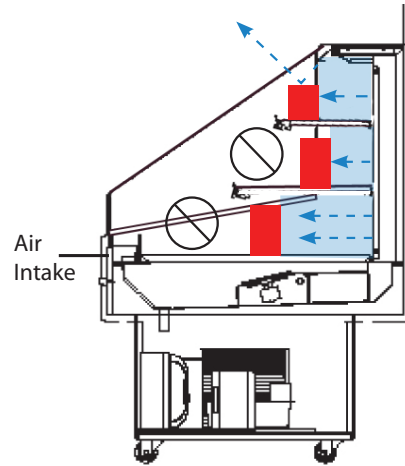

Loading End Cap Merchandisers

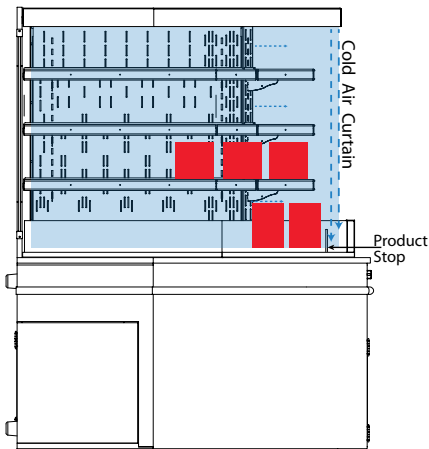

- Do not place product outside of the vertical air curtain line created by the merchandiser's canopy.
- Do not stack product or place containers so that they are touching each other or the vertical parts of the machine. Leave approximately 1" of air space between containers.
- Rotate product from back to front at regular intervals to help maintain constant product temperature.

Loading Grab-N-Go Merchandisers

Correct

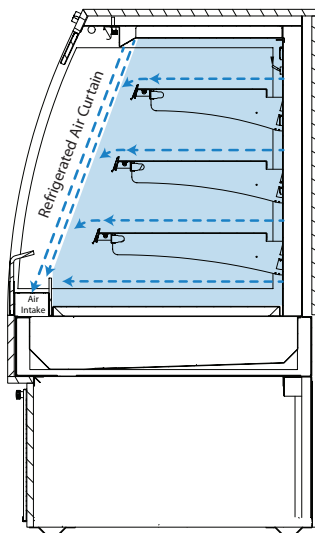

Wrong

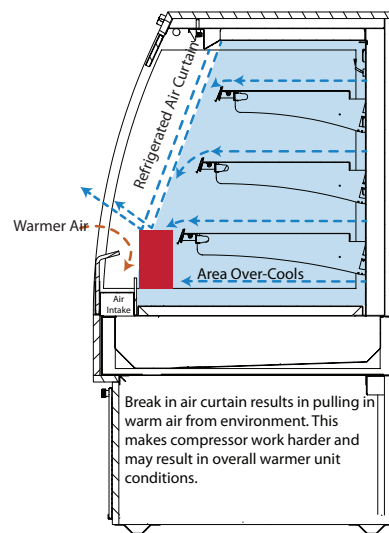

Break in air curtain results in pulling in warm air from environment. This makes compressor work harder and may result in overall warmer unit conditions.

Preventative Maintenance

The Condensing coil should be cleaned once every 30 days; this can be done by vacuuming the dust, dirt and debris from the coil after removing the grill cover. Failure to keep the condensing coil clean will cause the unit to fail to maintain temperature and can cause early compressor failure. If the coil has become impacted with dust, lint and dirt, it may need to be blown out by a qualified service tech.

Inside the drain pan should be kept clean and the drain screen kept free of trash and debris. Failure to do this can lead to excess water in the pan area which when in contact with evaporator coil can lead to the unit freezing and failure to maintain temperature.

All the grills along the base of the unit should be kept wiped down and free of trash, lint, dirt and debris. This allows the unit to circulate air for the condensing unit and failure to keep these clean can lead to premature failure of the refrigeration system.

Keep your unit clean by using a wet rag with warm water and mild detergent. Do not spray unit down with water.

Failure to maintain this unit can lead to loss of warranty and product failure.

If you have any questions on maintaining your unit please contact customer service.

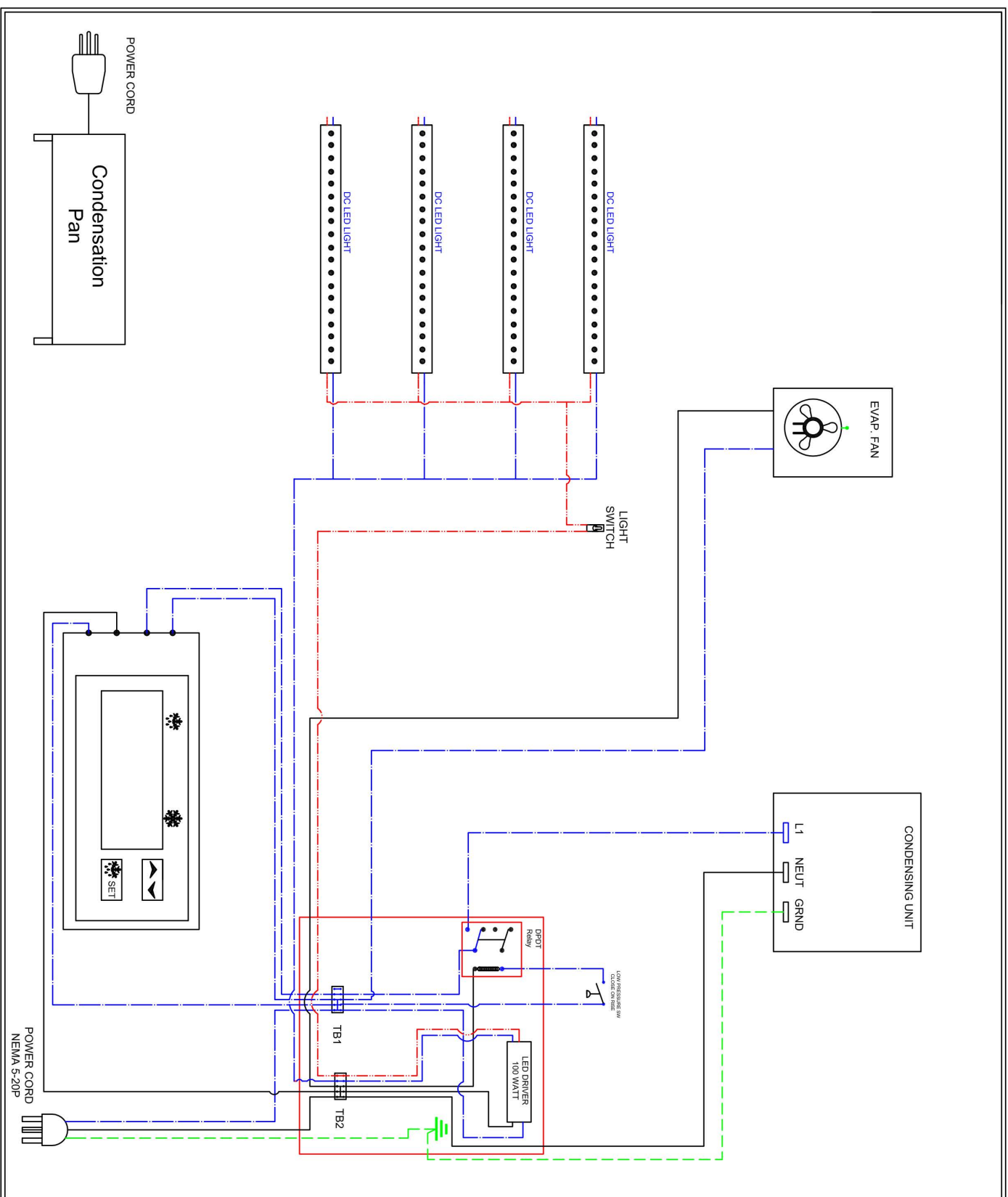

300 South 84TH AVE.
 WAUSAU, WI. 54401
 PH. (715) 842-2724
 FAX (715) 842-3125
 www.rdfixtures.com

WIRING DIAGRAM		
4' GRAB N GO		
DRAWN BY:	SCALE:	DATE:
DAVID	N/A	04/24/2013

SALES #	1	REVISIONS	SHEET 1
	2		
	3		

PIPER PRODUCTS, INC. LIMITED WARRANTY

All Piper products are warranted to be free of defects in material and workmanship for a period of 12 months from date of purchase on all parts and labor.

Piper Products, Inc. warrants to the original purchaser that its equipment will be free from defects in the materials and/or parts for a period of 12 months from date of shipment and reported to the factory.

The purchaser is responsible for having equipment properly installed, operated under normal conditions with proper supervision and to perform periodic preventative maintenance. Equipment failures caused by inadequate water quality, improper cleaning, harsh chemicals, or acids are not covered under warranty.

The manufacturer's obligation under this warranty shall be the replacement or repair of defective parts within the warranty period. Excessive labor (more than 1/2 hour) required to access Piper equipment built into cabinets, tables or structures by others, is NOT covered under labor warranty. Example: Piper multiple- or single-well food wells. All labor shall be performed during regular working hours. Overtime premium will be charged to buyer. After thorough examination, the decision of the Piper Products Service Department shall be final.

Any defective parts to be repaired or replaced must be returned to Piper Products, Inc., 300 South 84th Avenue, Wausau, WI 54401, transportation charges prepaid, and they must be properly packed and tagged. The serial and model number of the equipment and date of original installation of such equipment must be given. However, after one year we will not assume any responsibility for any expenses (including labor) incurred in the field incidental to the repair or replacement of equipment covered by this warranty. Our obligation hereunder to repair or replace a defective part is the exclusive remedy for breach of this warranty; and we will not be liable for any other damages or claims, including consequential damages.

If, upon inspection by Piper Products, Inc. or its Authorized Service Agency, it is determined that this equipment has not been properly installed or has not been used in an appropriate manner, has been modified, has not been properly maintained, the warranty will be void. Also, if the nameplate or other identifying marks have been removed, defaced or changed or the unit has been repaired or altered by persons other than expressly approved by Piper Products, Inc., the warranty will be void. If the equipment has been subjected to misuse or misapplication, neglect, abuse, accident, damage during transit or delivery, fire, flood, riot or acts of God, then this warranty shall also be void. When any situation occurs which voids the warranty the manufacturer shall not be liable for any damage to any person or any property which may result from the use of the equipment thereafter.

Warranty is limited to Piper manufactured products only and does not apply to other equipment which may be connected to or installed within.

No representative, dealer, distributor or any other person is authorized or permitted to make any other warranty or obligate Piper Products, Inc. to any liability not strictly in accordance with this policy.

This warranty is in lieu of all other warranties expressed or implied, including any warranty of merchantability, and fitness for a particular purpose. Piper Products does hereby exclude and shall not be liable to purchaser for any consequential or incidental damages including but not limited to damages to property, damages for loss of use, loss of time, loss of profits or income, resulting from any breach of warranty.

Page left intentionally blank



300 South 84th Avenue
Wausau, WI 54401
PHONE: 1-800-544-3057 & 1-715-842-2724
FAX: 1-715-842-3125

www.rdfixtures.com

FOR PARTS & SERVICE
Contact: Piper Products, Inc.
Phone: (800) 544-3057
Ask for Service Department