

APPLICATIONS

- Service Dry bakery/pastry case
- Curved front glass provides easy access for loading or cleaning
- Rear sliding doors for easy product loading

STANDARD FEATURES

CABINET CONSTRUCTION

- Unit built with steel frame and finished in high pressure laminated exterior panels.
- Removable Solid End Panels allow multiple units to be connected in an endless series.
- 1/4" thick tempered double bent curved glass with lift handle.
- Rear access clear sliding doors.
- Top to be 18 gauge stainless steel.
- 2 rows of protective 1" vinyl bumpers.

SHELVING

- Adjustable 1/4" thick tempered glass shelves and 18 gauge steel deck pans are easily removable.
- 3 standard shelves on all models + deck
- Full height shelf support pilasters with slotted holes on 1" centers for vertical shelf adjustments.
- Brackets allow shelf to be adjusted to 3 different angles to increase visibility.
- LED lights illuminate shelf area below

ELECTRICAL REQUIREMENTS

- Pre-wired and furnished with a junction box for use on a dedicated 120V, 60Hz, 1 phase circuit.

WARRANTY

- One year - Parts and Labor

OPTIONS / ACCESSORIES

- Powder coated interior and top.
- Mirrored Interior End Panels
- Assorted colors available for laminate, vinyl bumper and powder coat.
- Extra shelves
- Wire or sheet metal shelves
- Rear access mirrored sliding doors
- Front accent lighting
- Cord set instead of junction box

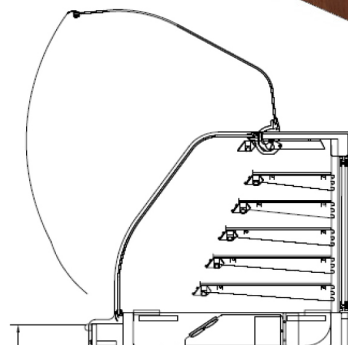
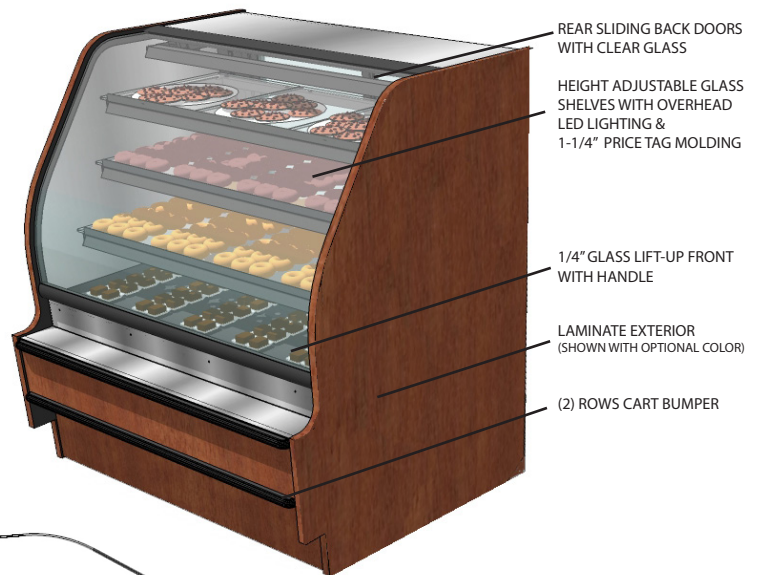

Front glass lifts for easy stocking and cleaning of display area

Engineered for stores with ambient conditions not to exceed 75°F and 55% relative humidity. Due to continuous improvements specifications may change without notice.

Built to meet the following specifications:



LINE DRAWINGS BASED ON A 6' (L) MODEL

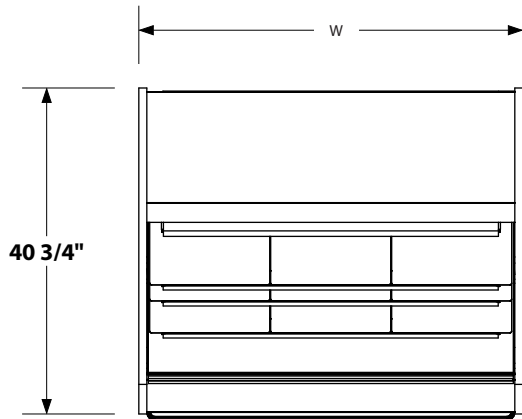

Top View

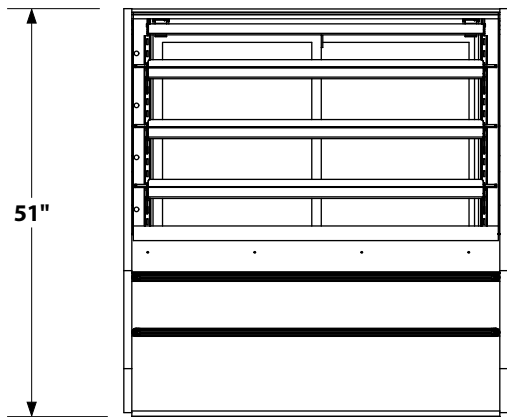

Front View

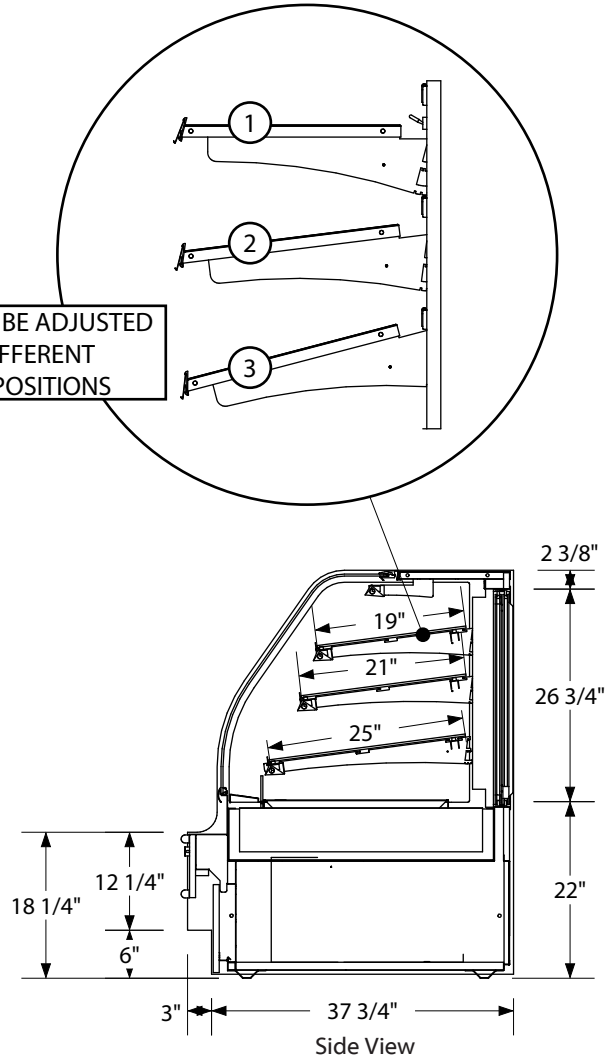

SHELVES CAN BE ADJUSTED TO (3) DIFFERENT ANGLED POSITIONS

Unit Width	Dimensions (inches)		
	W	D	H
48"	48 1/2	41 1/2	51 1/2
59"	59 1/2	41 1/2	51 1/2
77"	77 1/2	41 1/2	51 1/2

ELECTRICAL/REFRIGERATION SPECIFICATIONS - (BASED ON A 48" UNIT)

ELECTRICAL REQUIREMENTS - ON 6' CORD NEMA 15-15P PLUG						
QTY	DESCRIPTION	MANUFACTURER	MODEL #	VOLTAGE	AMPS EA	AMPS TOTAL
4	LIGHTS	ELECTRALED	EFDS-3-3500	120	0.17	.68
TOTAL ELECTRICAL REQUIRED IS 120/208 V, 60 Hz, 1 PH						.68